

**FJDBS 自润滑关节轴承**  
**FJDBS Metric Spherical Bushes**

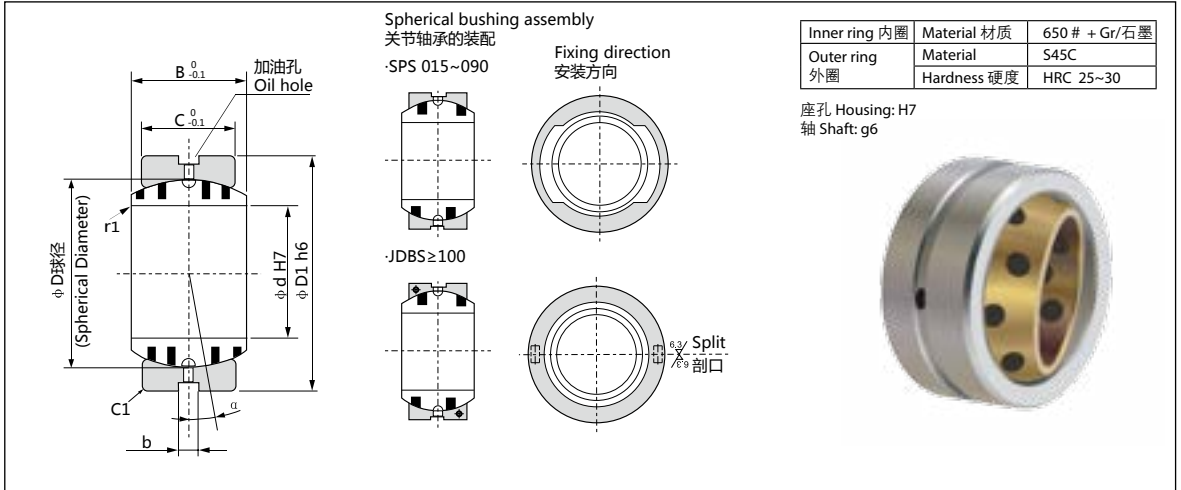

单位 unit: mm

型号规格 Standard No.	d	H7	D1	h6	B	C	D	b	调整角度 Alignment Angle $\alpha^\circ$	径向承载 Allowable Radial Load (kN)	径向承载 Allowable Thrust Load (kN)
FJDBS-015	15	$+0.018/0$	26	$0/-0.013$	12	9	22		8	6.5	0.5
FJDBS-020	20		32	$0/-0.016$	16	14	28		4	12.6	1.4
FJDBS-025	25	$+0.021/0$	42		21	18	36		5	21.8	2.5
FJDBS-030	30		50		27	23	44		6	32.0	3.5
FJDBS-035	35		55		30	26	49		5	43.7	4.8
FJDBS-040	40	$+0.025/0$	62	$0/-0.019$	33	28	55	4	6	54.7	5.7
FJDBS-045	45		72		36	31	62		5	69.7	7.2
FJDBS-050	50		80		42	36	70		-	92.4	10
FJDBS-060	60		100		53	45	90		6	143	16
FJDBS-070	70	$+0.030/0$	110	$0/-0.022$	58	50	99		5	181	20
FJDBS-080	80		130		70	60	115		6	254	30
FJDBS-090	90		140		76	65	125		-	313	36
FJDBS-100	100	$+0.035/0$	160	$0/-0.025$	88	75	145		-	544	64
FJDBS-110	110		170		93	80	155		5	642	73
FJDBS-120	120		190		105	90	17		6	797	94
FJDBS-130	130		200		110	95	180		5	880	105
FJDBS-140	140		210	$0/-0.029$	90	70	-	6	7	668	56
FJDBS-150	150	$+0.040/0$	220		120	105	200		5	1135	129
FJDBS-160	160		230		105	80	-		8	891	73
FJDBS-180	180		260	$0/-0.032$	105	-	225		6	1002	74
FJDBS-200	200		290		130	100	250		7	1434	117
FJDBS-220	220	$+0.046/0$	320		135	-	275		8	1577	118
FJDBS-240	240		340	$0/-0.036$	140	-	300		-	1720	-
FJDBS-260	260		370		150	110	325	9	7	2072	143
FJDBS-280	280	$+0.052/0$	400		155	120	350		6	2455	172
FJDBS-300	300		430	$0/-0.040$	165	120	375		7	2630	-